

Internal Use Only
050314

INSTRUCTION MANUAL

KADW Series: Models 5 through 25 scfm

Contents

1.0 GENERAL INFORMATION	1
2.0 DESCRIPTION	2
3.0 INSTALLATION	3
4.0 OPERATION	5
5.0 MAINTENANCE	7
WARRANTY	8

IMPORTANT READ PRIOR TO STARTING THIS EQUIPMENT

UNPACKING

This shipment has been thoroughly checked, packed and inspected before leaving our plant. It was received in good condition by the carrier and was so acknowledged.

- 1) Check for Visible Loss or Damage. If this shipment shows evidence of loss or damage at time of delivery to you, insist that a notation of this loss or damage be made on the delivery receipt by the carrier's agent.
- 2) Check for Concealed Loss or Damage. When a shipment has been delivered to you in apparent good order, but concealed damage is found upon unpacking, notify the carrier immediately and insist on his agent inspecting the shipment. Fifteen days from receipt of shipment is the maximum time limit for requesting such inspection. Concealed damage claims are not our responsibility as our terms are F.O.B. point of shipment.

1.0 General Information

CAUTION

- A. Pressurized devices-
This equipment is a pressure containing device.
 - Do not exceed maximum operating pressure as shown on equipment serial number tag.
 - Make sure equipment is depressurized before working on or disassembling it for servicing.
- B. Electrical-
This equipment requires electricity to operate.
 - Install equipment in compliance with national and local electrical codes.
- C. Breathing air-
 - Air treated by this equipment may not be suitable for breathing without further purification. Refer to OSHA standard 1910.134 for the requirements for breathing quality air.

KAESER

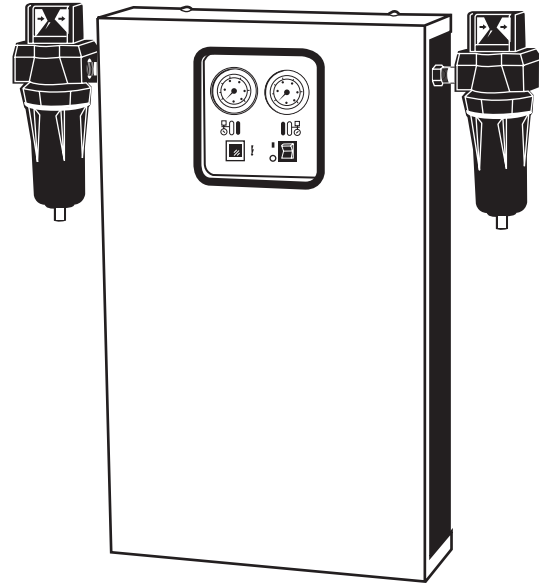

PRESSURE-

SWING (Heatless)

DESICCANT

COMPRESSED

AIR DRYERS

2.0 Description

2.1 Function

Dual tower regenerative desiccant dryers are utilized to dry compressed air to dew points below the freezing point of water or reduce the moisture content to low levels for use in critical process applications.

Air is dried by using two identical towers, each containing a desiccant bed. While one tower is on-stream drying the compressed air, the other tower is off-stream being regenerated (reactivated, i.e., dried out).

Desiccant dryers lower the dew point by adsorbing most of the water vapor present onto the surface of the desiccant. Adsorption occurs until an equilibrium is reached between the partial pressure of the water vapor in the air and that on the surface of the desiccant.

Desiccant can then be regenerated by desorbing the water collected on its surface. Regeneration occurs by expanding a portion of the dried air to atmospheric pressure. This very dry air (called purge air) causes the moisture to desorb from the desiccant and then carries the desorbed water out of the dryer.

2.2 Operation

Compressed air enters the dryer and is directed to TOWER 1 through valve (A) and then exits the dryer through shuttle valve (B). A portion of the dried air is throttled to near atmospheric pressure by means of an orifice (C). This extremely dry, low pressure air flows through and regenerates the desiccant in TOWER 2 and is then exhausted through purge/repressurization valve (D) and exhaust muffler (E) to atmosphere.

After a set time, the automatic solid state timer closes purge/repressurization valve (D) allowing TOWER 2 to repressurize slowly.

At the end of 5 minutes (when operating on a 10 minute cycle) or 2 minutes (when operating on a 4 minute cycle), valve (A) shifts and purge/repressurization valve (D) re-opens. The main air flow is now dried by TOWER 2 while TOWER 1 is regenerated.

NOTE: On models 5, 10, 15 - optional air-by-pass valve is installed inside cabinet. Make certain that valve is in desired mode (flow thru (dry) or by-pass).

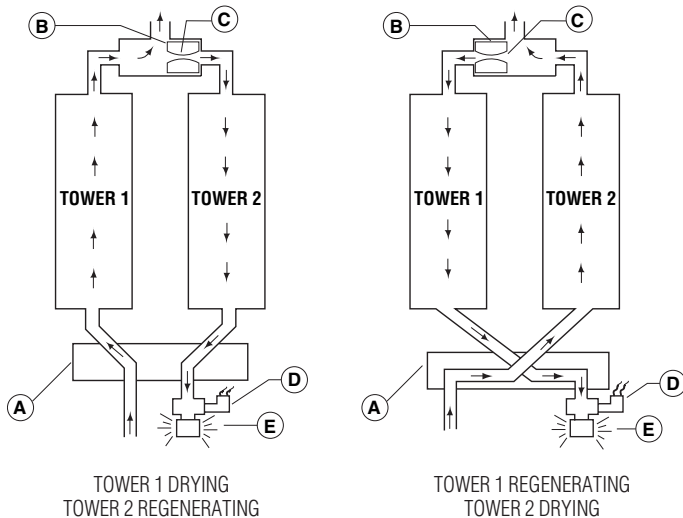
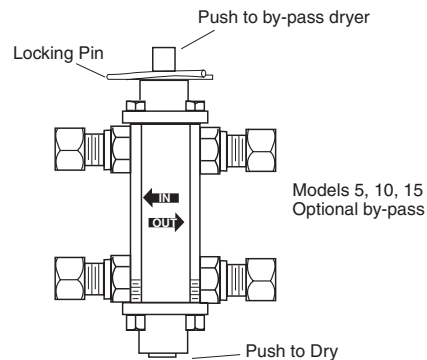

Figure 1 Flow Schematic



3.0 Installation

3.1 Dimensions, Connections, Weight

MODEL NUMBER	DIMENSIONS in (mm)										WEIGHT lb (kg)
	A	B	C	D	E	F	G	H	J	K	
5	30-5/8 (778)	20-1/8 (511)	1-13/16 (46)	15-1/4 (387)	6-11/16 (170)	3-3/4 (95)	1-1/2 (38)	1-1/2 (38)	3-3/4 (95)	3 (76)	82 (37)
10	30-5/8 (778)	20-1/8 (511)	1-13/16 (46)	15-1/4 (387)	6-11/16 (170)	3-3/4 (95)	1-1/2 (38)	1-1/2 (38)	3-3/4 (95)	3 (76)	119 (54)
15	30-5/8 (778)	20-1/8 (511)	1-13/16 (46)	15-1/4 (387)	6-11/16 (170)	3-3/4 (95)	1-1/2 (38)	1-1/2 (38)	3-3/4 (95)	3 (76)	136 (62)
20	36-5/8 (930)	26-1/8 (664)	1-11/16 (43)	21 (533)	8-9/16 (217)	6-3/4 (171)	4-1/4 (108)	1-1/4 (32)	4-1/4 (108)	5 (127)	171 (78)
25	36-5/8 (930)	26-1/8 (664)	1-11/16 (43)	21 (533)	8-9/16 (217)	6-3/4 (171)	4-1/4 (108)	1-1/4 (32)	4-1/4 (108)	5 (127)	196 (89)

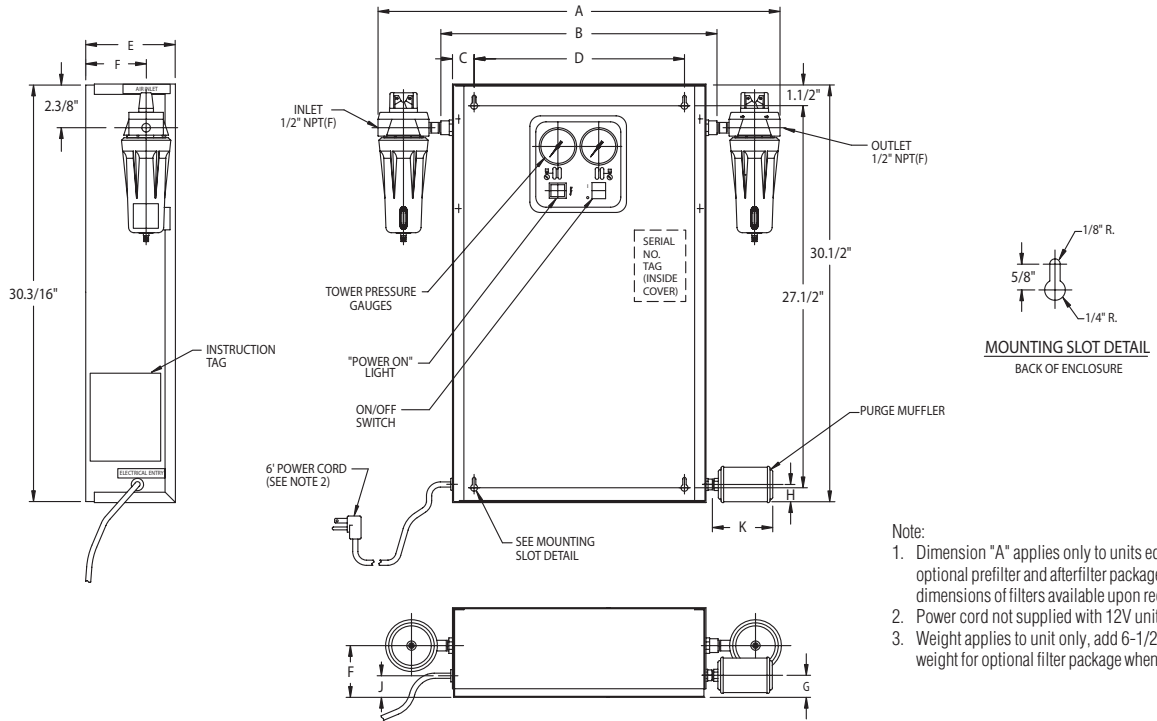

- Note:
1. Dimension "A" applies only to units equipped with optional prefilter and afterfilter package. Specific dimensions of filters available upon request.
 2. Power cord not supplied with 12V units.
 3. Weight applies to unit only, add 6-1/2 lbs. (3 kg) to weight for optional filter package when specified.

Figure 2 Dimensional Drawing

3.2 Electrical Specifications

MODEL	WATTS	AMPS	
		HOLDING	INRUSH
5	27.5	0.3	0.5
10	27.5	0.3	0.5
15	27.5	0.3	0.5
20	31.8	0.4	0.8
25	33.0	0.6	1.1

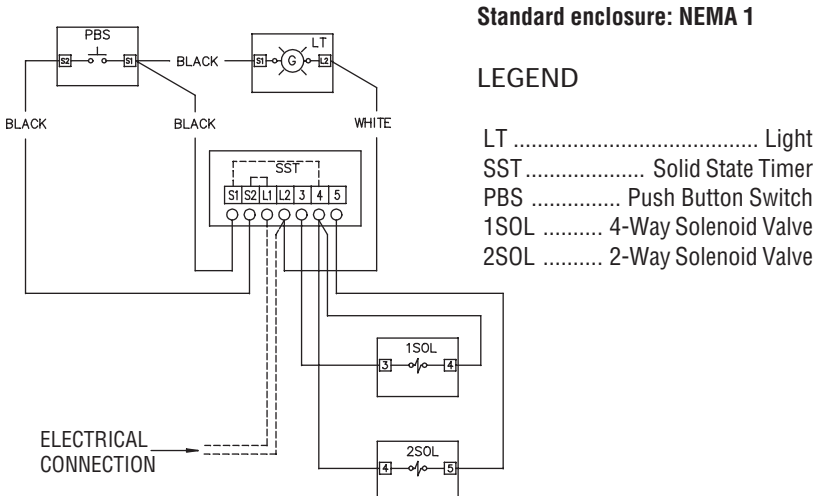

Standard enclosure: NEMA 1

LEGEND

- LT Light
 SST Solid State Timer
 PBS Push Button Switch
 1SOL 4-Way Solenoid Valve
 2SOL 2-Way Solenoid Valve

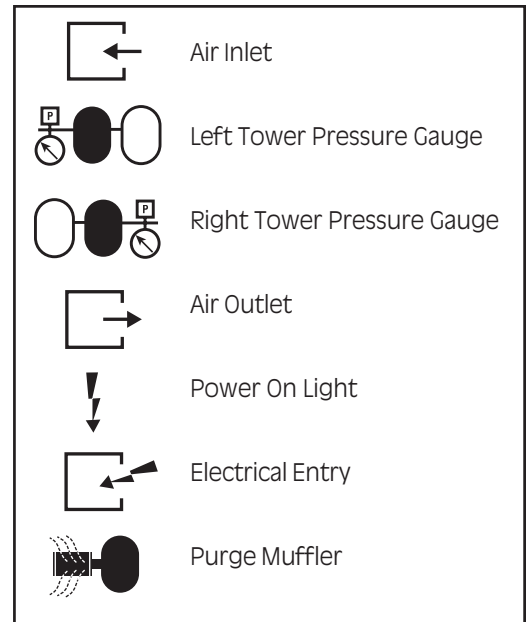

Maximum Operating Pressure:
150 psig, 10.5 kgf/cm²

Maximum Operating Temperature:
120°F, 49°C

Figure 3 Electrical Hook-up

3.3 Dryer Location in a Compressed Air System

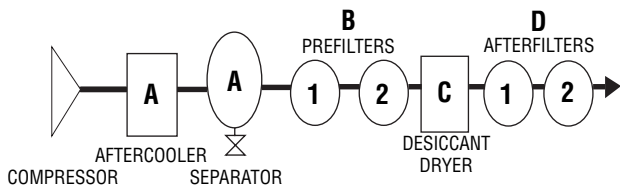

NOTE: Air Compressor should be adequately sized to handle air system demands as well as purge loss. Failure to take this into account could result in overloading air compressors and/or insufficient air supply downstream.

NOTE: It is desirable to install dryer where compressed air is at the lowest possible temperature (downstream of aftercoolers) and the highest possible pressure (upstream of pressure reducing valves) without exceeding the maximum working pressure.

A. Aftercooler/separator - Compressed air entering dryer must be cooled to at least 120°F (49°C). Use aftercooler and separator if higher temperatures are present.

NOTE: Installation of a refrigerated dryer ahead of a pressure-swing desiccant dryer does not increase desiccant dryer capacity or reduce purge flow requirements. However, if necessary, a cooling unit can be installed ahead of the desiccant dryer to reduce the inlet air temperature to the dryer, producing a correspondingly lower outlet dew point.

B. Prefilters - Adequate filtration is required upstream of the dryer in order to protect the desiccant bed from contamination. The following filters are recommended:

1. **Air Line Filter** - On compressed air systems utilizing non-lubricated (oil-free) air compressors, use to protect desiccant bed from solid and liquid contamination. On systems with lubricated compressors, if bulk liquid is present, use as a prefilter ahead of the oil aerosol removal filter.
2. **Oil Aerosol Removal Filter** - On systems with lubricated compressors, use to remove oil aerosols and protect desiccant bed from oil contamination.

C. Desiccant dryer

D. Afterfilters - To ensure downstream air purity (prevent desiccant dust from traveling downstream) adequate filtration down-stream of the dryer is required. Depending on the degree of purity you require from your compressed air system, the following filters are recommended:

1. **Air Line Filter** - Use as an afterfilter to remove desiccant fines and protect downstream components from solid particles 1 micron and larger. Filters for finer solid particle filtration are available.
2. **Oil Vapor Adsorber** - Use as an afterfilter to remove oil vapor and its subsequent taste and odor and to protect downstream components from solid particles 0.01 micron and larger.

NOTE: By-pass lines and isolation valves are recommended so that maintenance work can be performed without shutting off the air supply.

IMPORTANT: The compressed air supply inlet should be periodically checked to ensure that equipment design specifications are not exceeded. Normally the compressor installation includes intercoolers, aftercoolers, separators, receivers, or similar equipment which adequately pretreat the compressed air supply in order to avoid excessively high air temperatures and liquid slugging of down-stream equipment.

3.4 Pre and Afterfilter Installation

If supplied, install Prefilter and Afterfilter

NOTE: When installing, hold bulkhead fitting on dryer with wrench and thread filter on by hand.

- a. Install prefilter (KOR Series) ahead (upstream) of dryer. Use nipple supplied to connect filter to inlet port of dryer.
- b. Install afterfilter (KPF Series) downstream of dryer. Use nipple supplied to connect filter to outlet port of dryer.

NOTE: Observe arrows on differential pressure gauge to ensure proper flow direction through filter.

3.5 Wall-mounting

Four holes are provided in the rear of cabinet. Attach cabinet to wall using four (4): #14 round head wood screws; or #14 round or pan head machine screws; or #14 pan head self-tapping or sheet metal screws; or 1/4" round or pan head machine screws.

3.6 Piping

Connect air line from compressor to inlet of prefilter or dryer. Connect downstream air line to outlet of afterfilter or dryer.

3.7 Electrical connection

Check to see that power supply to dryer is the same as the power requirements indicated on the identification label. Install plug into receptacle of proper voltage or hardwire to pigtailed and ground screw inside cabinet.

3.8 Muffler Installation

Install muffler (shipped separately inside of cabinet) to fitting on side of cabinet.

3.9 Initial desiccant charge

The dryer is shipped complete with desiccant and ready to operate after piping and electrical connections are made.

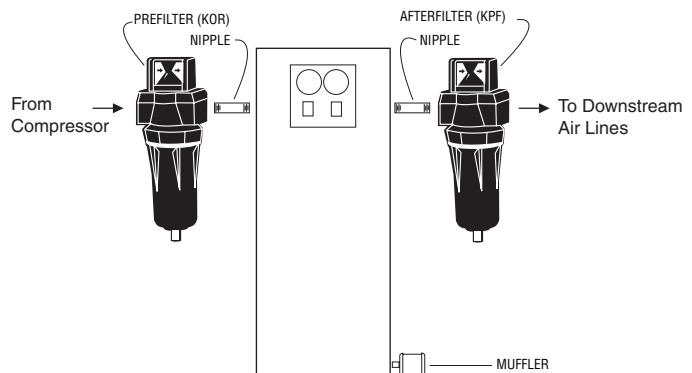

Figure 4

4.0 Operation

4.1 Start-up

- A. During the initial start-up, slowly pressurize dryer to full line pressure and check entire system for leaks. Depressurize and correct any leaks.
- B. Timer Board Setting - With the dryer de-energized, (Power-on light extinguished) verify position of the Cycle Time Jumpers. The jumpers are located on the timer board in the cabinet. Refer to Figure 5.
 1. Cycle Time Jumper - Determine the cycle time necessary to produce the desired dew point and set two jumpers as follows:
 - a. For a 10 Minute Cycle Position jumpers on terminals per Figure 5a.
 - b. For a 4 Minute Cycle Position jumpers on terminals per Figure 5b.
- C. Slowly pressurize the dryer.
- D. Energize the Dryer On-Off switch located on the enclosure door (Power-on light should illuminate).

NOTE: If dryer is installed with either internally or externally mounted air by-pass valve, make certain that by-pass valve is closed to prevent untreated air from flowing downstream.

4.2 Inlet, Purge, and Outlet Flows @ 100 psig (7 kgf/cm²)

- A. Inlet Flows
 1. Maximum Inlet Flow at Rated Conditions
For maximum inlet flow at rated conditions refer to Table 1.
 2. Maximum inlet flow at various pressures
To determine maximum inlet flow at inlet pressures other than 100 psig (7kgf/cm²), multiply inlet flow from Table 1 by multiplier from Table 2 that corresponds to system pressure at inlet of dryer.
- B. Purge Flow
 1. Maximum Purge Flow
Maximum Purge Flow (MFP) is the amount of purge flowing through the off-stream tower when the purge/repressurization valve is open. After the purge/repressurization valve closes, the purge flow will gradually decrease as the off-stream tower repressurizes to line pressure. Refer to Table 1 for Maximum Purge Flows at 100 psig (7kgf/cm²). Use column corresponding to the dryer cycle time setting (4 or 10 minutes).

TABLE 1

MODEL	CYCLE TIME	INLET FLOW (1)		PURGE FLOW (2)			
		scfm	m ³ /min	Average Purge Flow		Maximum Purge Flow	
				scfm	m ³ /min	scfm	m ³ /min
5	10	5	0.14	1.0	0.03	1.1	0.03
10	MINUTE	10	0.29	2.0	0.06	2.2	0.06
15	(-40°C	15	0.43	3.0	0.09	3.3	0.09
20	-40°F	20	0.57	4.0	0.11	4.4	0.13
25	PDP)	25	0.72	5.0	0.14	5.5	0.16
5	4	4.3	0.12	0.8	0.02	1.1	0.03
10	MINUTE	8.5	0.24	1.7	0.05	2.2	0.06
15	(-73°C	13	0.37	2.6	0.07	3.3	0.09
20	-100°F	17	0.49	3.4	0.10	4.4	0.13
25	PDP)	21	0.60	4.4	0.13	5.5	0.16

1. Inlet flows are established in accordance with CAGI (Compressed Air and Gas Institute) standard ADF-200, Dual Stage Regenerative Desiccant Compressed Air Dryers - Methods for Testing and Rating. Conditions for rating dryers are: inlet pressure - 100 psig (7 kgf/cm²); inlet temperature - saturated at 100°F (38°C).
2. Average Purge Flow is the total amount of air used to purge and repressurize off-stream towers averaged over the cycle time. Maximum Purge Flow is the flow rate through the off-stream tower during that portion of the cycle the purge/repressurization valve is open.

TABLE 2 Capacity Correction Factor for various inlet pressures

Inlet Pressure	psig	50	60	70	80	90	100	110	120	130	140	150
	kgf/cm ²	3.5	4.2	4.9	5.6	6.3	7.0	7.7	8.4	9.1	9.8	10.5
Multiplier		0.31	0.42	0.54	0.73	0.83	1.00	1.09	1.17	1.26	1.35	1.44

TABLE 3 Purge Flow Correction Factor for various inlet pressures

Inlet Pressure	psig	50	60	70	80	90	100	110	120	130	140	150
	kgf/cm ²	3.5	4.2	4.9	5.6	6.3	7.0	7.7	8.4	9.1	9.8	10.5
Multiplier		0.55	0.64	0.73	0.82	0.91	1.00	1.09	1.17	1.26	1.35	1.44

TABLE 4 Outlet pressure dew points at various inlet temperatures

INLET TEMP. °F (°C)	35 (1.7)	40 (4.4)	50 (10.1)	60 (15.6)	70 (21.1)	80 (26.7)	90 (32.2)	100 (37.8)	110 (43.3)	120 (48.9)
OUTLET P.D.P. °F (°C) 10 MIN CYCLE	-75 (-59.4)	-70 (-56.7)	-65 (-53.9)	-60 (-51.1)	-55 (-48.3)	-50 (-45.6)	-45 (-42.8)	-40 (-40.0)	-35 (-37.2)	-30 (-34.4)
OUTLET P.D.P. °F (°C) 4 MIN CYCLE	-149 (-100.6)	-145 (-98.3)	-138 (-94.4)	-130 (-90.0)	-122 (-85.6)	-115 (-81.7)	-108 (-77.8)	-100 (-73.3)	-92 (-68.9)	-85 (-65.0)

TABLE 5 Outlet pressure dew points at Moisture Indicator color change

INLET TEMP. °F (°C)	35 (1.7)	40 (4.4)	50 (10.1)	60 (15.6)	70 (21.1)	80 (26.7)	90 (32.2)	100 (37.8)	110 (43.3)	120 (48.9)
OUTLET P.D.P. °F (°C)	-34 (-36.7)	-28 (-33.4)	-22 (-30.0)	-16 (-26.7)	-10 (-23.4)	-4 (-20.0)	3 (-16.1)	9 (-12.8)	15 (-9.5)	21 (-6.1)

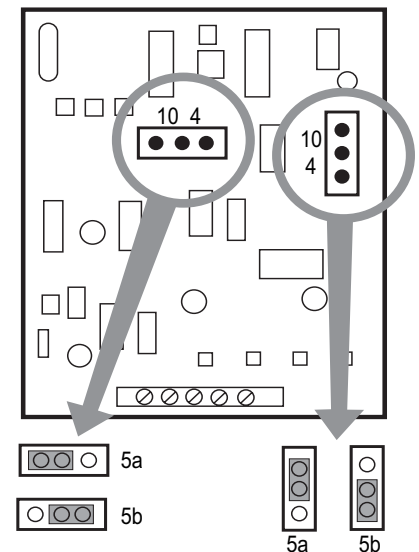

Figure 5

2. Average Purge Flow

The Average Purge Flow (APF) is the actual amount of flow averaged over the entire purge/repressurization cycle. It includes the maximum purge flow (MFP) for a set amount of the purge/repressurization time and the volume of air used for repressurization. Refer to Table 1 for Average Purge Flows at 100 psig. Use column corresponding to the dryer cycle time setting (4 or 10 minutes).

3. Purge flows at pressures other than 100 psig

To determine Maximum or Average Purge Flow at inlet pressures other than 100 psig, multiply purge flow at 100 psig from Table 1 by the multiplier from Table 3 that corresponds to system pressure at inlet to dryer.

C. Outlet Air Flow

1. Minimum Outlet Flow

Determine minimum outlet flow available from dryer by subtracting Maximum Purge Flow from inlet flow to dryer.

NOTE: Air compressor should be adequately sized to handle air system demands as well as purge loss. Failure to do so could result in overloading air compressors and/or insufficient air supply downstream.

2. Average Outlet Flow

Determine average outlet flow available by subtracting Average Purge Flow from inlet flow to dryer.

NOTE: Average outlet flow may be used to determine available downstream air supply if a storage vessel (receiver tank) of sufficient volume is available between dryer and point of air usage. Otherwise use 3.2.3.1 To compute downstream air available.

EXAMPLE:

Find maximum inlet flow, maximum and average purge flows, and minimum and average outlet flows for a 10 scfm unit operated at 120 psig on a 10 minute cycle. Dryer will operate with an inlet air flow of 11 scfm.

- Step 1: Find Maximum Inlet Flow by multiplying Maximum Inlet Flow at Rated Conditions from Table 1 by Inlet Pressure Correction Factor from Table 2: $10 \times 1.17 = 11.7$ scfm.
- Step 2: Find Maximum Purge Flow by multiplying Maximum Purge Flow at 100 psig from Table 1 by Purge Flow Correction Factor from Table 3: $2.2 \times 1.17 = 2.6$ scfm, the maximum purge flow.
- Step 3: Find Average Purge Flow by multiplying Average Purge Flow at 100 psig from Table 1 by Purge Flow Correction Factor from Table 3: $2.0 \times 1.17 = 2.3$ scfm, the average purge flow.
- Step 4: Find Minimum Outlet Flow available by subtracting Maximum Purge Flow (Step 2) from inlet flow of 11 scfm: $11 - 2.6 = 8.4$ scfm.
- Step 5: Find Average Outlet Flow available by subtracting Average Purge Flow (Step 3) from inlet flow of 11 scfm: $11 - 2.3 = 8.7$ scfm.

4.3 Operating Conditions

- A. Maximum Working Pressure: 150 psig (10.5 kgf/cm²)
- B. Minimum Working Pressure: 50 psig (3.5 kgf/cm²)
It is recommended that the air dryer be operated at the highest available pressure not exceeding the maximum working pressure since the dryer capacity increases and % of purge air decreases at higher pressures.
- C. Maximum Operating Temperature: 120°F (49°C)
- D. Outlet Pressure Dew Points
Outlet pressure dew points at various inlet compressed air temperatures: The outlet pressure dew point is determined by the compressed air temperature at the inlet to the dryer and cycle time. Use Table 4 to determine outlet dew points at corresponding inlet compressed air temperatures.

4.4 Operational Check Points

- A. Check periodically that there is power to the unit - Power on light is on.
- B. Periodically check tower pressure gauges to verify that valves are operating and sequencing correctly. Tower pressure gauge of tower on line should read line pressure. Tower pressure gauge of tower off line should read below 2 psig (0.14 kgf/cm²) while tower is purging.
- C. If unit is equipped with optional moisture indicator check every four hours. Outlet relative humidity of the desiccant dryer is indicated by the color change humidity indicator. Green indicates R.H. below 3% and yellow indicates R.H. above 3%. Table 5 indicates outlet dew point when moisture indicator changes from green to yellow at various inlet temperatures. During startup the indicator may be yellow, however, it should begin to change to green within 4 hours.
- D. If supplied with optional prefilter/afterfilter. Check that indicators are in green area. If indicator is in red area element replacement is necessary.

4.5 Dryer Shutdown

To shut down the dryer, de-energize using the on-off switch (Power-on light extinguished). Unit will remain pressurized.

4.6 Depressurization

- To depressurize unit
- A. Open by-pass valve (if one is installed) and close inlet and outlet valves.
- B. Run timer through a tower change cycle until pressure gauges on both towers read 0 psig (0 kgf/cm²).

10 MINUTE CYCLE

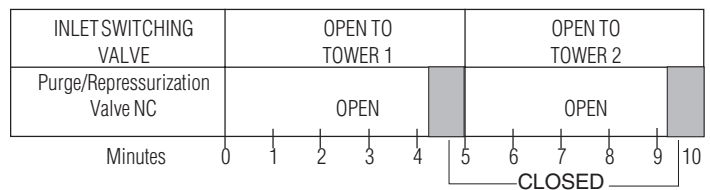

4 MINUTE CYCLE

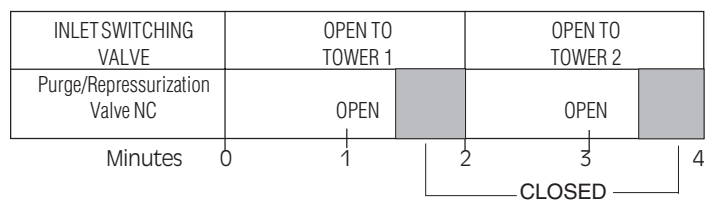

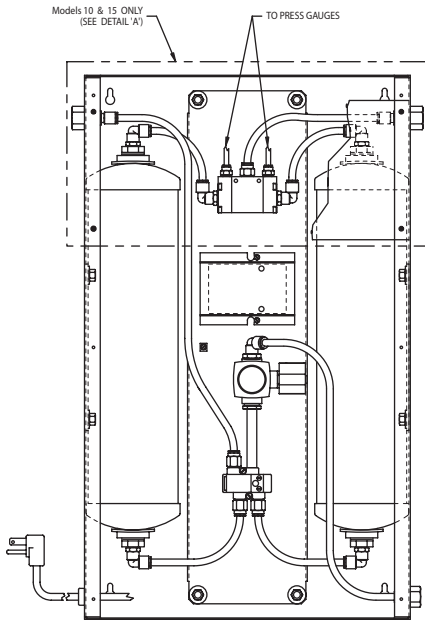

MODELS 5, 10 & 15

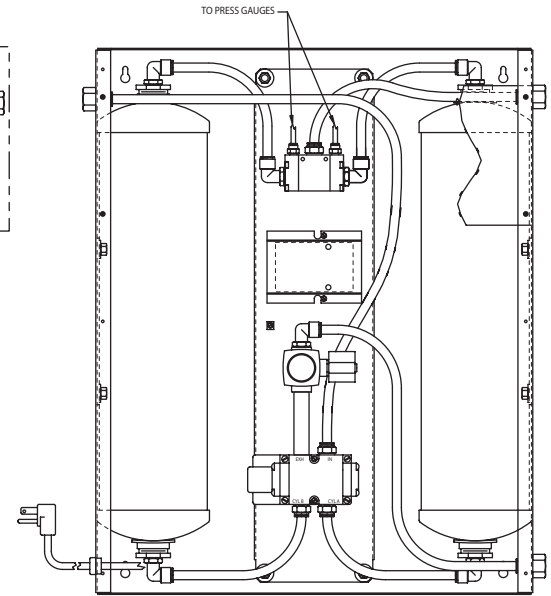
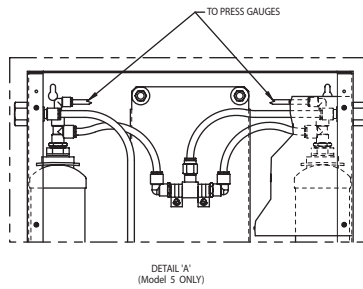

MODELS 20, & 25

5.0 Maintenance

CAUTION: The heatless desiccant dryer is a pressure containing device. Depressurize before servicing. (See section 4.6.)

5.1 Desiccant Replacement

IMPORTANT: The use of the correct replacement desiccant is necessary for proper drying operation. Never use hygroscopic salts of the type commonly used in "deliquescent" type dryers.

A. Frequency of Desiccant Replacement - Desiccant should be replaced whenever the required dew point cannot be maintained while the dryer is being operated within its design conditions and there are no mechanical malfunctions.

NOTE: Desiccant life is determined by the quality of the inlet air. Proper filtering of the inlet air will extend the life of the desiccant.

B. Procedure for Desiccant Replacement

1. Depressurize and de-energize the dryer.
2. Remove front panel from cabinet.
3. To replace spent desiccant, remove tubing from top and bottom of desiccant towers and unscrew strainer assemblies.

NOTE: Be prepared to catch the desiccant being removed in a container. Desiccant will readily pour out when drain port is opened.

4. Allow the spent desiccant to drain from the towers.
5. Replace bottom strainer assemblies using teflon tape sealant or equivalent.
6. Fill the desiccant drying towers as full as possible with dry desiccant.
7. Replace top strainer assemblies using teflon tape sealant or equivalent.

8. Reinstall tubing to top and bottom of desiccant towers.

C. Ensuring Desiccant Dryness

1. Replacement desiccant is shipped in air tight containers. Keep containers closed until use to avoid moisture contamination. If desiccant is exposed to air it can be heated in an oven at 400°F for four hours before use, or the next procedure can be used.
2. If the dryer is not refilled with dry desiccant, it will be necessary to operate the dryer on 100% purge for approximately twenty-four hours to dry the desiccant.

Amount of desiccant required for complete change

MODEL	DESICCANT REQUIRED	
	lb	(kg)
5	7	(3)
10	15	(7)
15	22	(10)
20	28	(13)
25	39	(18)

5.2 Prefilter/Afterfilter Maintenance

A. Element Replacement

1. For maximum filtration efficiency, replace element when pressure drop reaches 10 psi (0.7 kgf/cm²) (indicator in red area) or annually, whichever occurs first.

2. Procedure

WARNING: THIS FILTER IS A PRESSURE CONTAINING DEVICE. DEPRESSURIZE BEFORE SERVICING. If filter has not been depressurized before disassembly, an audible alarm will sound when the bowl begins to be removed from the head. If this occurs, stop disassembly, isolate and completely depressurize filter before proceeding.

1. Isolate filter (close inlet and outlet valves if installed) or shut off air supply.
2. Depressurize filter by slowly opening manual drain valve.

3. Remove bowl by pushing bowl up, turning bowl 1/8th turn to your left, and pulling bowl straight down.
4. Clean filter bowl.
5. Replace element.
 - a. Pull off old element and discard.
 - b. Make certain o-ring inside top of replacement element is in place and push element onto filter head.

NOTE: Prefilter - Do not handle element by outside foam cover. Handle by bottom end cap only.

6. After making certain that o-ring and wave spring inside top of bowl are in place, reassemble bowl to head.

NOTE: Make certain o-ring is generously lubricated.

NOTE: Wave spring ends should be pointed down to prevent the wave spring from interfering with reassembly.

B. Auto Drain Mechanism Replacement

Prefilter only: It is recommended that drain mechanism be replaced annually.

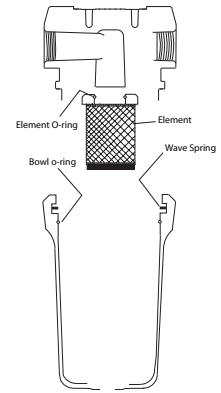

5.3 Repair Parts

PART	MODEL				
	5	10	15	20	25
PRESSURE GAUGE	3160138	3160138	3160138	3160138	3160138
STRAINER (TOP & BOTTOM)	3160171	3160171	3160171	3160171	3160171
MUFFLER	3048056	3048056	3048056	3133635	3133635
SHUTTLE VALVE	4010076	3159335	3159334	3159333	3159075
REPAIR KIT (SHUTTLE VALVE)	—	3161564	3161565	3161566	3161567
SWITCH (ON/OFF)	4010931	4010931	4010931	4010931	4010931
TIMER 115V	4010695	4010695	4010695	4010695	4010695
TIMER 230V	4010697	4010697	4010697	4010697	4010697
LIGHT (POWER ON) 115V	4011055	4011055	4011055	4011055	4011055
LIGHT (POWER ON) 230V	4011056	4011056	4011056	4011056	4011056
P/R VALVE 115V	3159717	3159717	3159717	3159717	3159717
P/R VALVE 230V	3159803	3159803	3159803	3159803	3159803
SWITCHING VALVE 115V	4009873	4009873	4009873	4009874	4009874
SWITCHING VALVE 230V	4009875	4009875	4009875	4009876	4009876
REPAIR KIT (SWITCHING VALVE)	3152280	3152280	3152280	3152281	3152281
REPLACEMENT ELEMENT - PREFILTER (KOR-35)	OR-35	OR-35	OR-35	OR-35	OR-35
REPLACEMENT ELEMENT - AFTERFILTER (KPF-35)	PF-35	PF-35	PF-35	PF-35	PF-35
REPLACEMENT DRAIN - PREFILTER	3152270	3152270	3152270	3152270	3152270

WARRANTY

The manufacturer warrants the product manufactured by it, when properly installed, operated, applied, and maintained in accordance with procedures and recommendations outlined in manufacturer's instruction manuals, to be free from defects in material or workmanship for a period of one (1) year from the date of shipment to the buyer by the manufacturer or manufacturer's authorized distributor, or eighteen months from the date of shipment from the factory, whichever occurs first, provided such defect is discovered and brought to the manufacturer's attention within the aforesaid warranty period. The manufacturer will repair or replace any product or part determined to be defective by the manufacturer within the warranty period, provided such defect occurred in normal service and not as a result of misuse, abuse, neglect or accident.

The warranty covers parts and labor for the warranty period. Repair or replacement shall be made at the factory or the installation site, at the sole option of the manufacturer. Any service performed on the product by anyone other than the manufacturer must first be authorized by the manufacturer. Normal maintenance items requiring routine replacement are not warranted. Unauthorized service voids the warranty and any resulting charge or subsequent claim will not be paid. Products repaired or replaced under warranty shall be warranted for the unexpired portion of the warranty applying to the original product. The foregoing is the exclusive remedy of any buyer of the manufacturer's product. The maximum damages liability of the manufacturer is the original purchase price of the product or part.

THE FOREGOING WARRANTY IS EXCLUSIVE AND IN LIEU OF ALL OTHER WARRANTIES, WHETHER WRITTEN, ORAL, OR STATUTORY, AND IS EXPRESSED IN LIEU OF THE IMPLIED WARRANTY OF MERCHANTABILITY AND THE IMPLIED WARRANTY OF FITNESS FOR A PARTICULAR PURPOSE. THE MANUFACTURER SHALL NOT BE LIABLE FOR LOSS OR DAMAGE BY REASON OF STRICT LIABILITY IN TORT OR ITS NEGLIGENCE IN WHATEVER MANNER INCLUDING DESIGN, MANUFACTURE OR INSPECTION OF THE EQUIPMENT OR ITS FAILURE TO DISCOVER, REPORT, REPAIR, OR MODIFY LATENT DEFECTS INHERENT THEREIN. THE MANUFACTURER, HIS REPRESENTATIVE OR DISTRIBUTOR SHALL NOT BE LIABLE FOR LOSS OF USE OF THE PRODUCT OR OTHER INCIDENTAL OR CONSEQUENTIAL COSTS, EXPENSES, OR DAMAGES INCURRED BY THE BUYER, WHETHER ARISING FROM BREACH OF WARRANTY, NEGLIGENCE OR STRICT LIABILITY IN TORT.

The manufacturer does not warrant any product, part, material, component, or accessory manufactured by others and sold or supplied in connection with the sale of manufacturer's products.

01/01/93

AUTHORIZATION FROM THE SERVICE DEPARTMENT IS NECESSARY BEFORE MATERIAL IS RETURNED TO THE FACTORY OR IN-WARRANTY REPAIRS ARE MADE.

SERVICE DEPARTMENT: (724) 745-3038

KAESER

www.kaeser.com

KAESER COMPRESSORS

U.S.A. • P.O. Box 946 • Fredericksburg, VA 22404 • Tel: 540/898-5500 • Fax: 540/898-5520 • Service: (724) 745-3038

Canada • 3760 Rue La Verendrye • Boisbriand (Quebec) J7H 1R5 • Tel: 450/971-1414 • Fax: 450/971-1415 • Service: (724) 745-3038

KAESER COMPRESORES, S.A. de C.V.

Mexico • Calle 2, No. 111 Locales EYF • Parque Industrial Jurica • 76100 Querétaro, QRO Mexico • Tel: 52-42-18-64-48 • Fax: 52-42-18-64-49

KAESER KOMPRESSOREN

Austria • Ges.m.b.H. • A-4031 Linz, Dallingergstr.8 • Telefon: (43) 732/38 60 51-0 • Fax: (43) 732/38 67 80 • Service: (43) 732/38 60 51-0

Singapore • 81 Tech Park Crescent • Tuas Tech Park • Singapore 638067 • Tel: (65) 68857733 • Fax: (65) 68857700 • 24-Hour Hotline: (65) 96838200